



AIS Class B Transceiver



The **AIT-202A** is an affordable AIS Class-B transceiver designed primarily for fishing vessels, small commercial craft and pleasure boats that are not mandatorily required to carry full function AIS Class-A transponders on board. Interfaced with an existing ECDIS or a PC, the **AIT-202A** operates as a low-cost, user-friendly navigational aid for avoidance of collision with other AIS-equipped vessels located beyond line-of-sight areas as well as close-in ranges.

Featuring:

- Dual receiver type AIS Class-B transceiver for non-SOLAS vessels
- Interoperable with AIS Class-A and other shipborne AIS Class-B systems
- Type-approved by EU-Notified Body*1 as IEC 60945 non-protected equipment category unit
- Shows various types of information*2 on surrounding vessels in real time, graphically or in the form of a detailed alphanumeric list across PC*3 or ECDIS screen.
- Simple to install and equipped with interface ports for direct connection with a VHF antenna, a GPS sensor, NMEA0183/NMEA-2000 and RS-232C data transfer devices
- The Viewer software supplied in a CD allows AIS-format data received from surrounding vessels to be monitored on a *Windows-based PC, showing graphically those vessels in different symbols and colors across a simulated Radar screen, or listing a detailed alphanumeric set of data (MMSI, name, range, speed, CPA/TCPA, Lat/Long, length, beam, vessel & cargo types, etc.) for each AIS vessel.

Specifications:

- Frequency Range: 156.025 to 162.025 MHz, 25 kHz spacing
- Number of AIS Transmitter: 1
- Number of AIS Receiver: 2 (one RX time-shared with DSC)
- Modulation & Baud Rate: GMSK, 9600 bps
- AIS Channels: CH 87B/161.975 MHz, CH 88B/162.025 MHz
- DSC Channel: CH 70, 1300/2100 Hz FSK, 1200 bps
- Transmit Power: Approx. 2W
- Message Format: Compliant with AIS Class A & B messages
- Interface Ports: NMEA0183(RS-422), USB, NMEA2000
- Antenna Ports: for GPS (TNC) and VHF antenna (SO-239)
- Waterproofing: IPX2
- 50 CH GPS receiver (IEC61108-1 Compliant)
- Ambient Temperature: -15 to 55°C operating (95% RH w/o condensation), -25 to 70°C storage
- Power Requirements: 12/24 DC, approx. 3W @12V
- Weight: Approx. 250g
- Dimensions: 128W X 36H X 88D mm, connectors included
- Compliant Standards: IMO MSC.74(69), IMO MSC.112(73), IEC 60945 Ed.4, IEC 61108-1 Ed.1, IEC 62287-1 Ed.2, IEC 61162-1 Ed.3, IEC 61162-2 Ed.1, IEC60529 Ed.2.1, IEC 60068-2-52 ed.2, IIEC 60950-1
- EU Type Approval: AIS Class B, approved by BSH
- Software Package: AIS Configuration (for setup) and AIS Viewer, supplied in CD

*1: BSH (Bundesamt für Seeschifffahrt und Hydrographie)

*2: MMSI, vessel's name, callsign, range, bearing, speed, heading, CPA/TCPA, LAT/LONG, ROT, length, beam, alarm, destination, ETA, vessel type, cargo type, etc.

*3: Windows platform with JMC-supplied Viewer installed. Windows is a registered trademark of Microsoft Corp.

NOTE: Specifications are subject to change without notice or obligation to users of previous versions.



AIS Class B Transceiver Model AIT-202A

External Connections

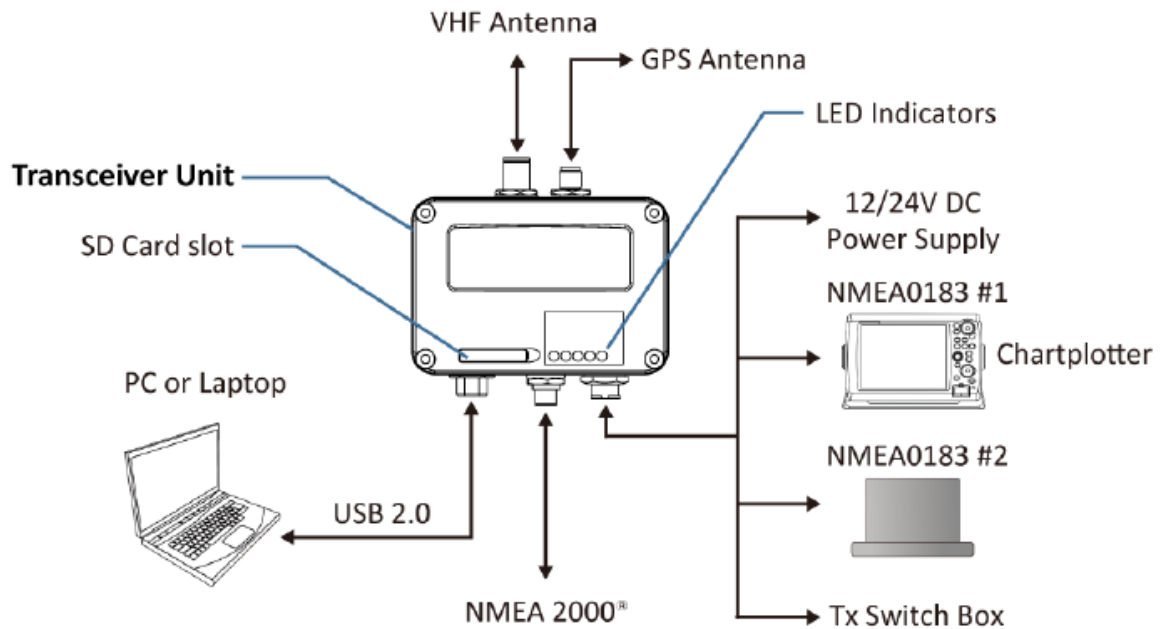

Dimensions

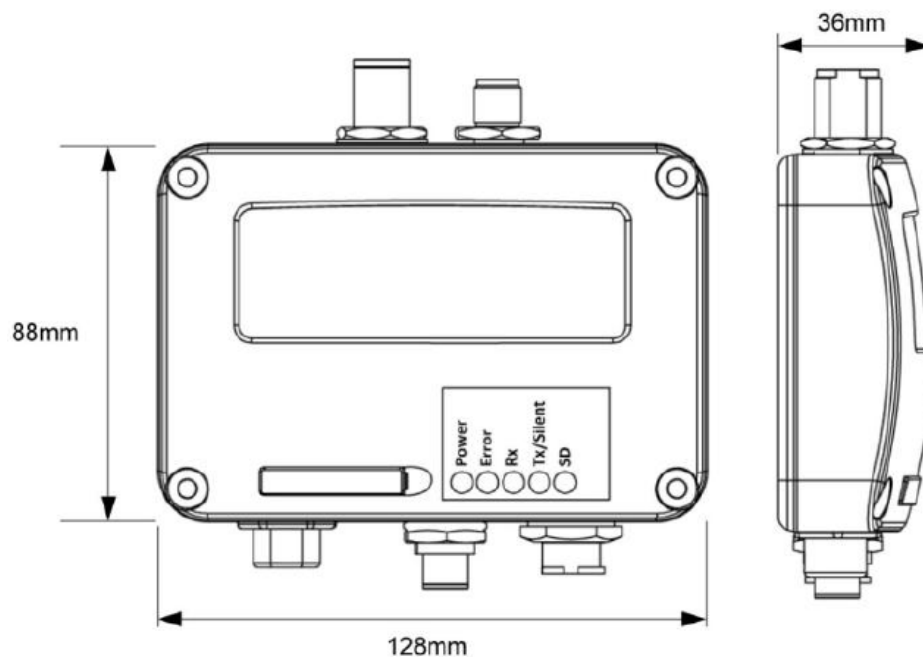

Japan Marina Co., Ltd.

36-2-1001 Udagawa-cho, Shibuya-ku, Tokyo, 150-0042 Japan
Phone: +81-3-3461-3606 / Telefax: +81-3-3496-2078 E-mail: sales@japan-marina.co.jp
Web site: www.japan-marina.co.jp

Printed in Japan